

iPAC-5010 Linux-based Programmable Automation Controller

- ✓ Pre-built Linux 2.6.x OS with file system
- ✓ 180MHz ARM9 CPU, 64MB SDRAM and 16MB Flash
- ✓ 16x opto-isolated digital inputs
- ✓ 8x Darlington-pair digital outputs to drive external relays
- ✓ Two 10/100Mbps Ethernet ports
- ✓ One RS-232 port, one RS-485 port
- ✓ Two USB 2.0 host ports for add-on functionality expansion
- ✓ One SD memory card slot included for storage expansion
- ✓ GNU C/C++ tool chain for Linux/Windows environment
- ✓ 9-40VDC input range



Introduction

The iPAC-5010 is a Linux-based, network-enabled and Web-ready programmable automation controller. It features rich digital inputs/outputs for real-world I/O controls.

☒ Open and standard programming environment

The iPAC-5010 is a true Linux computing platform with file system support. Users can operate the iPAC-5010 the same way as they do on a normal Linux desktop.

Open-source GNU Tool Chain, including C/C++ cross-compiler and POSIX standard C/C++ library, is bundled with the iPAC-5010 for free.

☒ Network enabled and Web ready

The iPAC-5010 provides two 10/100Mbps Ethernet ports. A sophisticated Web server is pre-installed for users to implement applications which need Web-based remote monitor and controls. In addition, it is easy to add IEEE-802.11b/g WiFi support through the iPAC-5010's USB 2.0 ports.

☒ High-speed serial interface

Also, the iPAC-5010 provides one RS-232 and one RS-485 serial ports, running up to 921.6kbps. The RS-485 port supports hardware direction control.

☒ Opto-isolated digital inputs

The iPAC-5010 provides 16 channels of isolated digital input with opto-isolation protection up to 2500Vrms to ensure the iPAC-5010 can work properly in noisy industrial environment. Each input channel comes with a on/off status LED.

☒ Darlington-pair digital outputs

The iPAC-5010 provides 8 channels of Darlington-pair digital output, which can drive external relays directly. Each output channel comes with a on/off status LED.

☒ Optional 4GB SD Card for Data Storage

Users can install one standard SD Flash memory card, up to 4GB now, into the iPAC-5010 as an additional hard drive.

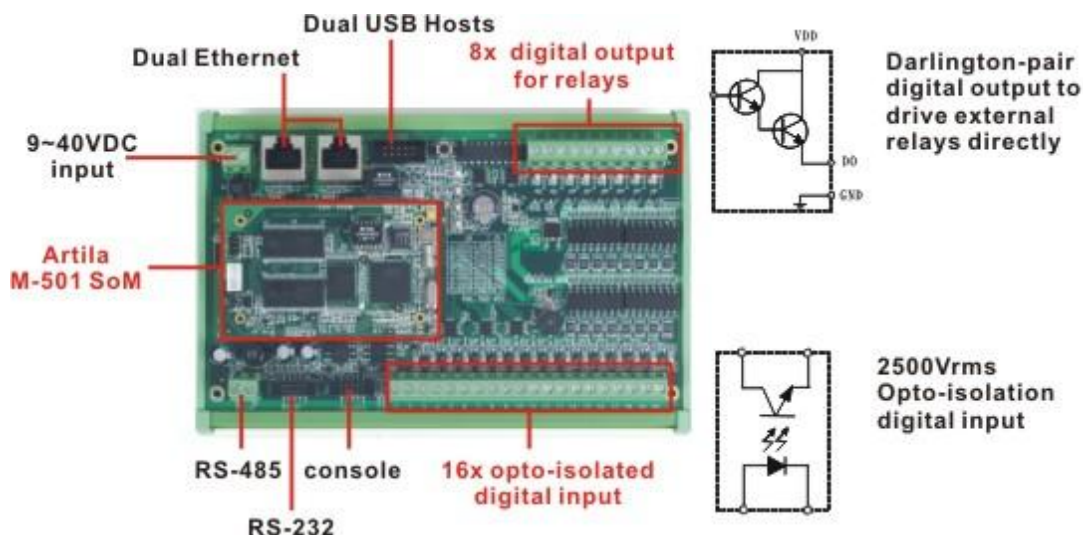

H/W Specifications

CPU/Memory

- ▶ CPU: ATMEL 180MHz AT91RM9200 (ARM9, w/MMU)
- ▶ Memory: 64MB SDRAM, 16MB Flash

Network Interface

- ▶ Two 10/100BaseT, RJ-45 connector

TTY (Serial) Ports

- ▶ RS-485: one port, with screw-fixed wiring terminal
Signals: Data+, Data-, GND
- ▶ RS-232: one port, with 10P header
Signals: Tx, Rx, RTS, CTS, DSR, DTR, DCD, GND
- ▶ Cosole: one port, with 10P header
Signals: Tx, Rx, GND

TTY (Serial) Port Parameters

- ▶ Baud Rate: up to 921.6 Kbps
- ▶ Parity: None, Even, Odd, Mark, Space
- ▶ Data Bits: 5,6,7,8
- ▶ Stop Bit: 1, 1.5, 2 bits
- ▶ Flow Control: RTS/CTS, XON/XOFF, None

USB Host Ports

- ▶ Two USB 2.0 compliant hosts, with 10P header
- ▶ Data rate: up to 12Mbps

Mass Storage

- ▶ One SD 1.0 compliant socket inside

General

- ▶ WatchDog Timer: yes, for kernel use
- ▶ Real Time Clock: yes
- ▶ Buzzer: yes
- ▶ Power input: 9~40VDC
- ▶ Power consumption: 800mA@12VDC
- ▶ Dimension: 160 x 104 x 32mm
- ▶ Operation Temperature: 0 to 70C(32 to 158F)
- ▶ Regulation: CE Class A, FCC Class A

Digital I/O Specifications

Isolated Digital Input

- ▶ No. of channels: 16
- ▶ Logical high: 5 ~ 24VDC
- ▶ Logical low: 0 ~ 1.5VDC
- ▶ Input resistance: 1.2k ohms@0.5W
- ▶ Response time: 20us
- ▶ Opto-isolation: 2500Vrms

Digital Output

- ▶ No. of channels: 8
- ▶ Source driver: UDN2981A (Allegro)
- ▶ Source voltage (VDD): 5~50VDC
- ▶ Output current: 500mA max.

S/W Specifications

General

- ▶ OS: Linux, kernel 2.6.x
- ▶ Boot Loader: U-Boot 1.1.2
- ▶ File Systems: JFFS2, ETX2/ETX3, VFAT/FAT, NFS

Protocol stacks

- ▶ IPv4, ICMP, ARP, DHCP, NTP, TCP, UDP, FTP, Telnet, HTTP, PPP, PPPoE, CHAP, PAP, SMTP, SNMP V1/V2, SSL, SSH 1.0/2.0

Utilities

- ▶ bash: shell command
- ▶ tinylogin: login and user manager utility
- ▶ telnet: Telnet client program
- ▶ busybox: Linux utility collection
- ▶ ftp: FTP client program

Daemon

- ▶ pppd: Dial In/out over serial port and PPPoE
- ▶ snmpd: SNMP agent program
- ▶ telnetd: Telnet server program
- ▶ inetd: TCP server program
- ▶ ftpd: FTP server program
- ▶ boa: Web server program
- ▶ sshd: secured shell server
- ▶ iptables: Firewall service manager
- ▶ armd: Artila manager daemon

Tool Chain for Linux

- ▶ GCC: C/C++ PC cross compiler for Linux, CygWin
- ▶ GLIBC: POSIX Library

Device Drivers

- ▶ SD/MMC, UART, Real Time Clock, Buzzer, Digital I/O, Ethernet, Watchdog Timer

USB Host Drivers (could be customized)

- ▶ Flash disk
- ▶ WiFi (IEEE-802.11b/g)
- ▶ RS-232 adaptors

Ordering Information

☒ IPAC-5010

Linux-based Programmable Automation Controller, with 8x digital outputs and 16x isolated digital inputs